

Laser distance sensor

OPTIMESS S2 CCD



- High measuring rate
- Meets the highest requirements
- Digital processing of measured values
- Analog output or CAN bus

The opto-electronic sensor OPTIMESS S2 is a device for non-contact distance measurement. This sensor distinguishes itself by a great independence of the measurement accuracy on different material surfaces and from the ambient light.

The OPTIMESS S2 works according to the triangulation principle. The laser spot projected by a laser diode via an optical system is represented at an angle on a linescan image sensor by a receiving optical system. The processor integrated in the sensor processes the optical distance information and outputs them as an analog value or via the CAN bus.



Robotics

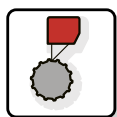

Profile measurement



Steel industry, industrial automation



Railroad systems



Dynamic contour measurement

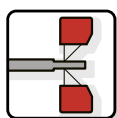

Thickness measurement



Rubber and tire industry

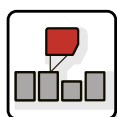

Distance measurement, position control



Car industry

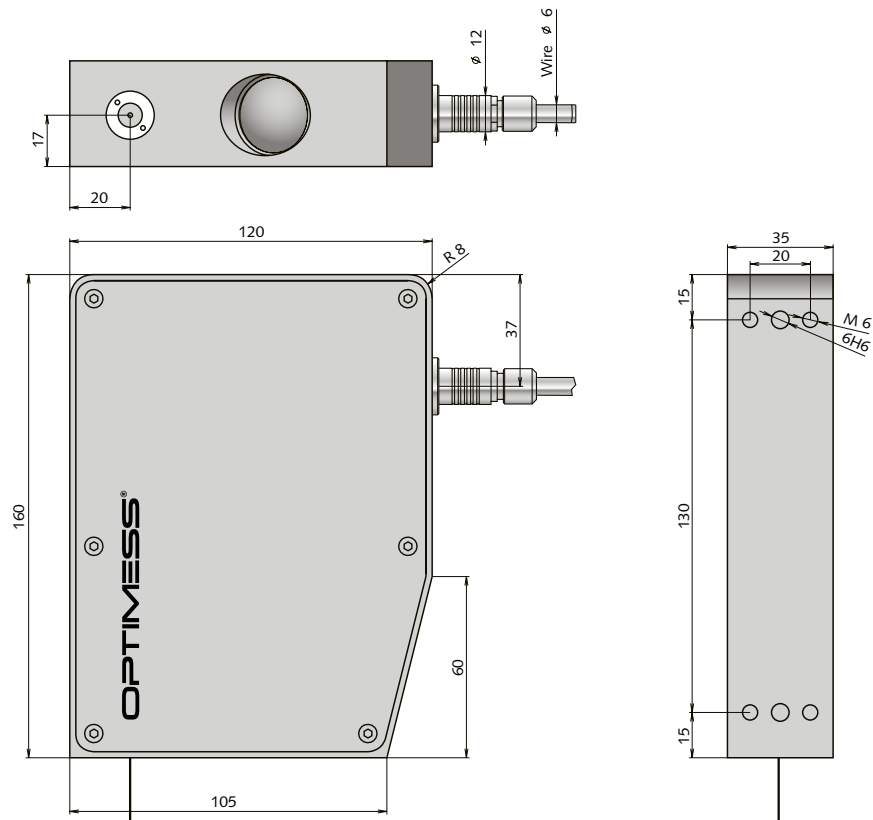

Technical data

	OMS 5508	OMS 5520	OMS 5540	OMS 5580	OMS 5620	OMS 5700
Measuring range [mm] [3]	8	20	40	80	120	200
Stand off [mm] [3]	50	100	150	200	300	400
Resolution [mm] [1]	0.002	0.004	0.010	0.020	0.030	0.050
Linearity	≤ ± 0.06% FSO					
Reproductibility	≤ ± 0.03% FSO					
Bandwidth [2]	20 kHz max.					
Filter [2]	Digital averaging					
Measuring rate	20 kHz max.					
Light source	Laser diode					
Spot diameter [2]	0.05–5 mm					
Wave-length [2]	660–780 nm					
Laser safety class [2]	2 / 3R / 3B					
Photo detector	CMOS Linear image sensor					
Supply voltage	± 15 V / 120 mA, ± 5% or 12–30 V / 120 mA [4]					
Output [2]	± 5 V / ± 10 V / 0–5 V / 0–10 V / 0–20 mA / 4–20 mA / CAN - Bus					
Operating temperature	-20°C bis 50°C (no condensation)					
Dimensions	120 x 160 x 35 mm					
Weight	approx. 900 g					
Protection class	IP 65 (without protection unit: IP 54)					

[1] Standard settings with filter 200Hz [2] Factory-set depending on the application [3] Other types upon request
 [4] only unipolar output and CAN Bus